

DCL 551



Stainless Steel Probe with RS485 Modbus RTU

Ceramic Sensor

accuracy according to IEC 60770:
standard: 0.35 % FSO
option: 0.25 % FSO

Nominal pressure

from 0 ... 40 cmH₂O up to 0 ... 200 mH₂O

Output signal

RS485 with Modbus RTU protocol

Special characteristics

- ▶ diameter 39.5 mm
- ▶ excellent long term stability
- ▶ especially for sewage,
viscous and pasty media
- ▶ reset function

Optional version

- ▶ diaphragm ceramics
Al₂O₃ 99,9%

The stainless steel probe DCL 551 with RS485 interface uses the communication protocol Modbus RTU which has found the way in industrial communication as an open protocol. The Modbus protocol is based on a master slave architecture with which up to 247 slaves can be questioned by a master – the data are transferred in binary form.

DCL 551 has been designed for hydrostatic level measurement in sewage as well as for viscous and pasty media.

Basic element is a robust and high overpressure capable capacitive ceramic sensor.

Preferred areas of use are



Sewage

waste water treatment
water recycling



Fuel and oil

level monitoring in open tanks
with low filling heights
fuel storage
tank farms / biogas plants



Modbus®

DCL 551

Stainless Steel Probe with RS485 Modbus RTU

Technical Data

Input pressure range																
Nominal pressure gauge	[bar]	0.04	0.06	0.1	0.16	0.25	0.4	0.6	1	1.6	2.5	4	6	10	16	20
Level	[mH ₂ O]	0.4	0.6	1	1.6	2.5	4	6	10	16	25	40	60	100	160	200
Overpressure	[bar]	2	2	4	4	6	6	8	8	15	25	25	35	35	45	45
Max. ambient pressure (housing): 40 bar																

Output signal	
Digital (pressure and temperature)	RS485 with Modbus RTU protocol

Supply	
Direct current	V _s = 9 ... 32 V _{DC}

Performance	
Accuracy ¹	standard: ≤ ± 0.35 % FSO option: ≤ ± 0.25 % FSO
Long term stability	≤ ± 0.1 % FSO / year at reference conditions
Measuring rate	500 Hz
Delay time	500 msec

¹ accuracy according to IEC 60770 – limit point adjustment (non-linearity, hysteresis, repeatability)

Thermal effects (offset and span)	
Tolerance band	≤ ± 1 % FSO
in compensated range	-20 ... 80 °C

Permissible temperatures	
Permissible temperatures	medium / storage: -25 ... 125 °C

Electrical protection ²	
Short-circuit protection	permanent
Reverse polarity protection	no damage, but also no function
Electromagnetic compatibility	emission and immunity according to EN 61326

² additional external overvoltage protection unit in terminal box KL 1 or KL 2 with atmospheric pressure reference available on request

Electrical connection	
Cable with sheath material ³	PUR (-25 ... 70 °C) black Ø 7.4 mm
Cable capacitance	signal line/shield also signal line/signal line: 160 pF/m
Cable inductance	signal line/shield also signal line/signal line: 1 µH/m
Bending radius	static installation: 10-fold cable diameter dynamic application: 20-fold cable diameter

³ shielded cable with integrated ventilation tube for atmospheric pressure reference

Materials (media wetted)	
Housing	stainless steel 1.4404 (316 L)
Seals	FKM others on request
Diaphragm	standard: ceramics Al ₂ O ₃ 96 % option: ceramics Al ₂ O ₃ 99.9 %
Protection cap	POM-C
Cable sheath	PUR

Miscellaneous	
Adjustable units	pressure: mmH ₂ O, mmHg, PSI, bar, mbar, g/cm ² , kg/cm ² , Pa, kPa, torr, atm, mH ₂ O, MPa
Read out	serial number; date of calibration, min- and max-value for pressure
Current consumption	max. 10 mA
Weight	approx. 400 g (without cable)
Ingress protection	IP 68
CE-conformity	EMC Directive: 2014/30/EU

Wiring diagram

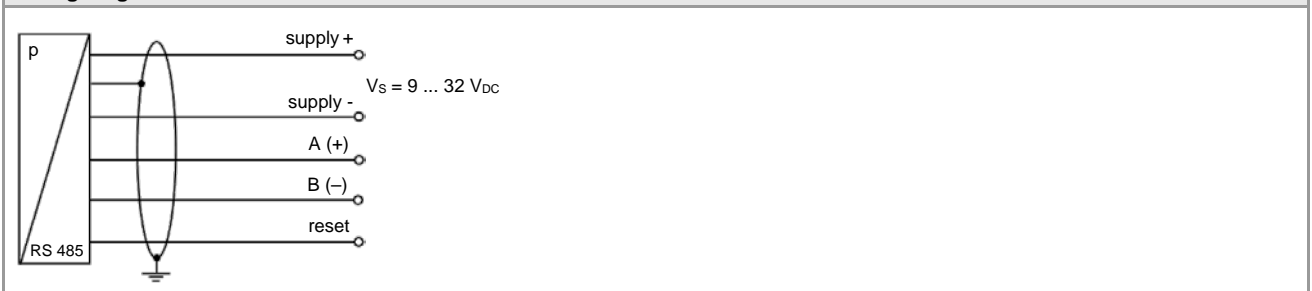

DCL 551

Stainless Steel Probe with RS485 Modbus RTU

Technical Data

Pin configuration	
Electrical connection	cable colours (IEC 60757)
Supply +	WH (white)
Supply -	BN (brown)
A +	GN (green)
B -	YE (yellow)
Reset	PK (pink)
Shield	GNYE (green yellow)
Dimensions (mm / in)	

Configuration Modbus RTU					
Standard configuration	001	-	1	-	1
Address					
Address	001				
	...				
	247				
Baud Rate					
4800 Bd			0		
9600 Bd			1		
19200 Bd			2		
38400 Bd			3		
Parity					
None					0
Odd					1
Even					2
Configuration code (to specify with order)		-		-	

Mounting flange with cable gland

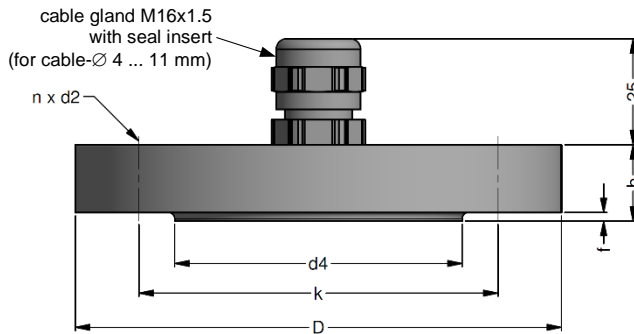

dimensions in mm			
size	DN25 / PN40	DN50 / PN40	DN80 / PN16
b	18	20	20
D	115	165	200
d2	14	18	18
d4	68	102	138
f	2	3	3
k	85	125	160
n	4	4	8

Technical data

Suitable for	all probes		
Flange material	stainless steel 1.4404 (316L)		
Material of cable gland	standard: brass, nickel plated on request: stainless steel 1.4305 (303); plastic		
Seal insert	material: TPE (ingress protection IP 68)		
Hole pattern	according to DIN 2507		

Ordering type	Ordering code	Weight
DN25 / PN40 with cable gland brass, nickel plated	ZMF2540	1.4 kg
DN50 / PN40 with cable gland brass, nickel plated	ZMF5040	3.2 kg
DN80 / PN16 with cable gland brass, nickel plated	ZMF8016	4.8 kg

Terminal clamp



Technical data

Suitable for	all probes with cable Ø 5.5 ... 10.5 mm		
Material of housing	standard: steel, zinc plated optionally: stainless steel 1.4301 (304)		
Material of clamping jaws and positioning clips	PA (fibre-glass reinforced)		
Dimensions (mm)	174 x 45 x 32		
Hook diameter	20 mm		

Ordering type	Ordering code	Weight
Terminal clamp, steel, zinc plated	Z100528	approx. 160 g
Terminal clamp, stainless steel 1.4301 (304)	Z100527	

