

Electronic Pressure Switch DS 230

Electronic Digital Pressure Gauge DM 230



www.bdsensors.com

Headquarter Western Europe / International

BD SENSORS GmbH
BD-Sensors-Str. 1
D - 95199 Thierstein
Germany
Tel: +49 (0) 92 35 / 98 11-0
Fax: +49 (0) 92 35 / 98 11-11

Headquarter Eastern Europe Russia

BD SENSORS s.r.o. Hradištská 817
CZ - 687 08 Buchlovice
Czech Republic
Tel: +42 (0) 5 72 / 4 11-0 11
Fax: +42 (0) 5 72 / 4 11-4 97

BD SENSORS RUS
39a, Varshavskoe shosse
RU - Moscow 117105
Russia
Tel: +7 (0) 9 59 81 / 09 63
Fax: +7 (0) 9 57 95 / 07 21

further agencies in:

- | | |
|--|--|
| EUROPE | ASIA |
| <ul style="list-style-type: none"> Belgium Denmark France Greece Italy Lithuania Luxemburg Netherlands Norway | <ul style="list-style-type: none"> Poland Romania Sweden Switzerland Slovakia Spain Turkey UK Ukraine |
- AUSTRALIA**
- Iran
 - Israel
 - Kazakhstan
 - Taiwan
 - Thailand

The addresses of our distribution partners are listed on our homepage www.bdsensors.com. It is possible to download data sheets, operating manuals, ordering codes and certificates, as well.

Table of contents

1. General information
2. Product identification
3. Mechanical installation
4. Electrical Installation
5. Initial start-up
6. Operation
7. Placing out of service
8. Maintenance
9. Service / Repair
10. Disposal
11. Warranty conditions
12. Declaration of conformity / CE

1. General information

1.1 Information on the operating manual

This operating manual contains important information on proper usage of the device. Read this operating manual carefully before installing and starting up the pressure measuring device.

Adhere to the safety notes and operating instructions which are given in the operating manual. Additionally applicable regulations regarding occupational safety, accident prevention as well as national installation standards and engineering rules must be complied with!

This operating manual is part of the device, must be kept nearest its location, always accessible to all employees.

This operating manual is copyrighted. The contents of this operating manual reflect the version available at the time of printing. It has been issued to our best knowledge. However, errors may have occurred. BD SENSORS is not liable for any incorrect statements and their effects.

– Technical modifications reserved –

1.2 Symbols used

- DANGER!** – dangerous situation, which may result in death or serious injuries
- WARNING!** – potentially dangerous situation, which may result in death or serious injuries
- CAUTION!** – potentially dangerous situation, which may result in minor injuries
- CAUTION!** – potentially dangerous situation, which may result in physical damage
- NOTE** – tips and information to ensure a failure-free operation

1.3 Target group

WARNING! To avoid operator hazards and damages of the device, the following instructions have to be worked out by qualified technical personnel.

1.4 Limitation of liability

By non-observance of the operating manual, inappropriate use, modification or damage, no liability is assumed and warranty claims will be excluded.

1.5 Intended use

- The electronic pressure switch DS 230 has been exclusively designed for OEM-customers for the basic equipment of e.g. pneumatics, pumps and hydraulic systems. It is equipped with a 4-digit LED-display to show the current system pressure. It is the operator's responsibility to check and verify the suitability of the device for the intended application. If any doubts remain, please contact our sales department in order to ensure proper usage. BD SENSORS is not liable for any incorrect selections and their effects!
- It has to be ensured, that the used medium is compatible with the media wetted parts.
- The technical data listed in the current data sheet are engaging and must be complied with. If the data sheet is not available, please order or download it from our homepage. (<http://www.bdsensors.com/products/download/datasheets>)

WARNING! – Danger through improper usage!

1.6 Package contents

Please verify that all listed parts are undamaged included in the delivery and check for consistency specified in your order:

- electronic pressure switch DS 230 or electronic digital pressure gauge DM 230
- for mechanical pressure ports DIN 3852: o-ring (pre-assembled)
- mounting instructions

2. Product identification

The device can be identified by its manufacturing label. It provides the most important data. By the ordering code the product can be clearly identified. The programme version of the firmware, (e. g. P01) will appear for about 1 second in the display after starting up the device. Please hold it ready for inquiry calls.

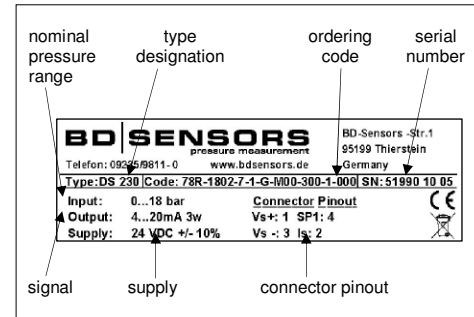

Fig. 1 manufacturing label

! The manufacturing label must not be removed from the device!

3. Mechanical installation

3.1 Mounting and safety instructions

- WARNING!** Install the device only when depressurized and currentless!
- WARNING!** This device may only be installed by qualified technical personnel who has read and understood the operating manual!
- Handle this high-sensitive electronic precision measuring device with care, both in packed and unpacked condition!
- There are no modifications/changes to be made on the device.
- Do not throw the package/device!
- To avoid damaging the diaphragm, remove packaging and protective cap only directly before starting up the device. A delivered protective cap must be stored!
- Place the protective cap on the pressure port again immediately after disassembling.
- Do not use any force when installing the device to prevent damage of the device and the plant!
- The display and the plastic housing are equipped with rotational limiters. Please do only rotate the display or the housing within the limit.
- For installations outdoor and in damp areas following these instructions:
 - Note the specified ingress protection in the data sheet!
 - To prevent moisture admission in the plug the device should be installed electrically after mounting, at once. Otherwise a moisture admission has to be blocked e.g. by using a suitable protection cap. (The ingress protection in the data sheet is valid for the connected device.)

- Take note that no assembly stress occurs at the pressure port, since this may cause a shifting of the characteristic curve.
- In hydraulic systems, position the device in such a way that the pressure port points upward (ventilation).
- Provide a cooling line when using the device in steam piping.
- If installing the device outdoor and there is any danger of lightning or overpressure we suggest putting a overpressure protection unit between the supply/switch cabinet and the device to prevent damage.

3.2 General installation steps

- Carefully remove the pressure measuring device from the package and dispose of the package properly.
- Go ahead as detailed in the specific instructions below.

3.3 Installation steps for DIN 3852

- Check to ensure the proper groove fitting of the o-ring and additionally to ensure no damage to the o-ring.
- Ensure that the sealing surface of the taking part is perfectly smooth and clean.
- Screw the device into the corresponding thread by hand.
- Tighten it with a wrench (approx. 5 Nm).

3.4 Installation steps for NPT

- Use a suitable seal, corresponding to the medium and the pressure input (e. g. a PTFE-strip).
- Screw the device into the corresponding thread by hand.
- Tighten it with a wrench (approx. 30 Nm).

3.5 Positioning of the display module

The display module is rotatable so that clear readability is guaranteed even on unusual installation positions. The display module can be turned as shown below.

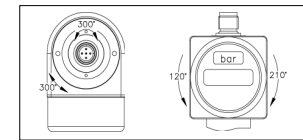

Fig. 2 display module

4. Electrical installation

WARNING! Install the device only when depressurized and currentless!

Establish the electrical connection of the device according to the technical data shown on the manufacturing label, the pin configuration and the wiring diagram.

Pin configuration DS 230

Electrical connections	M12x1 (5-pin) plastic
Supply +	1
Supply -	3
Signal +	2
Contact 1	4
Contact 2	5
Shield	via pressure port

Wiring diagram DS 230

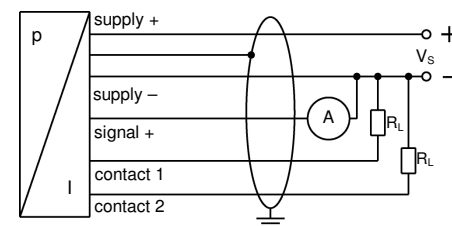

Pin configuration DM 230

Electrical connections	3-wire-system	4-wire-system	without analogue output
Supply +	1	1	1
Supply -	3	3	2
Signal +	2	internal connected	-
Signal -	-		4
Shield	4 and via pressure port	via pressure port	4 and via pressure port

Wiring diagrams DM 230

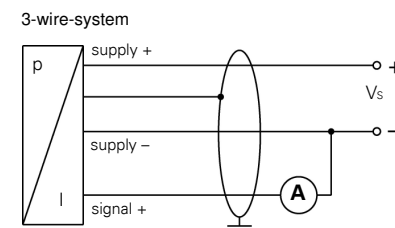

4-wire-system

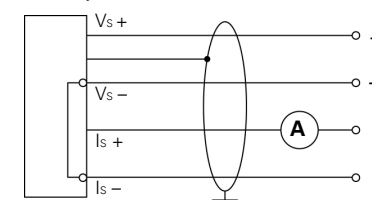

without analogue output

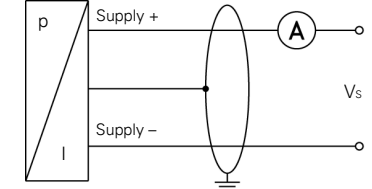

For the electrical connection, a shielded and twisted multicore cable is recommended.

5. Initial start-up

- WARNING!** Before start-up, the user has to check for proper installation and for any visible defects.
- WARNING!** The device can be started and operated by authorized personnel only, who have read and understood the operating manual!
- WARNING!** The device has to be used within the technical specifications, only! (check the technical data in the data sheet!)

6. Operation

6.1 Operating and display elements

DS 230

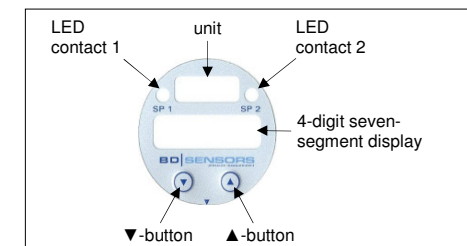

Fig. 3 touchpad for device with two contacts

The device has, according to the order max. two LEDs which are allocated to the resp. contacts. The LEDs will light up when the respective set point has been reached and the contact is active. The display of the measured value as well as the configuration of the individual parameters occurs menu-driven via the seven-segment display.

DM 230

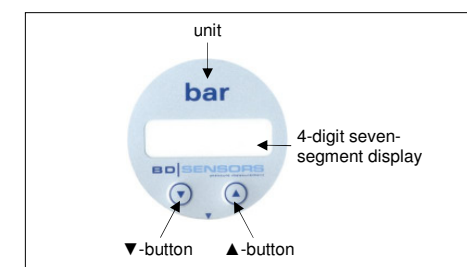

Fig. 4 touchpad

The display of the measured value as well as the configuration of the individual parameters occurs menu-driven via the seven-segment display.

6.2 Configuration

The menu system is a closed system allowing you to scroll both forward and backward through the individual set-up menu to navigate to the desired setting item. All settings are permanently stored in an EEPROM and therefore available again even after disconnecting from the supply voltage. The structure of the menu system is the same for all types of devices, regardless of the number of contacts. However, they only differ by the number of menus. Following figure and the menu list shows all possible menus.

Please follow the manual meticulously and remember that changes of the adjustable parameters (switch-on point, switch-off point, etc.) become only effective after pushing both buttons simultaneously and leaving the menu item.

6.3 Password system

To avoid a configuration by unauthorized persons, the possibility is given to lock the device by an access protection. More information is given in menu 1 of the menu list.

6.4. Description of hysteresis and compare mode

To invert the respective modes, you have to exchange the values for the switch-on and switch-off points.

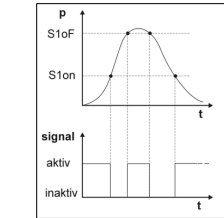

Fig. 5 compare mode inverted

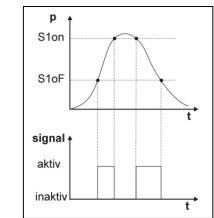

Fig. 6 compare mode

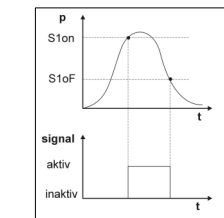

Fig. 7 hysteresis mode

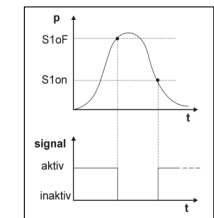
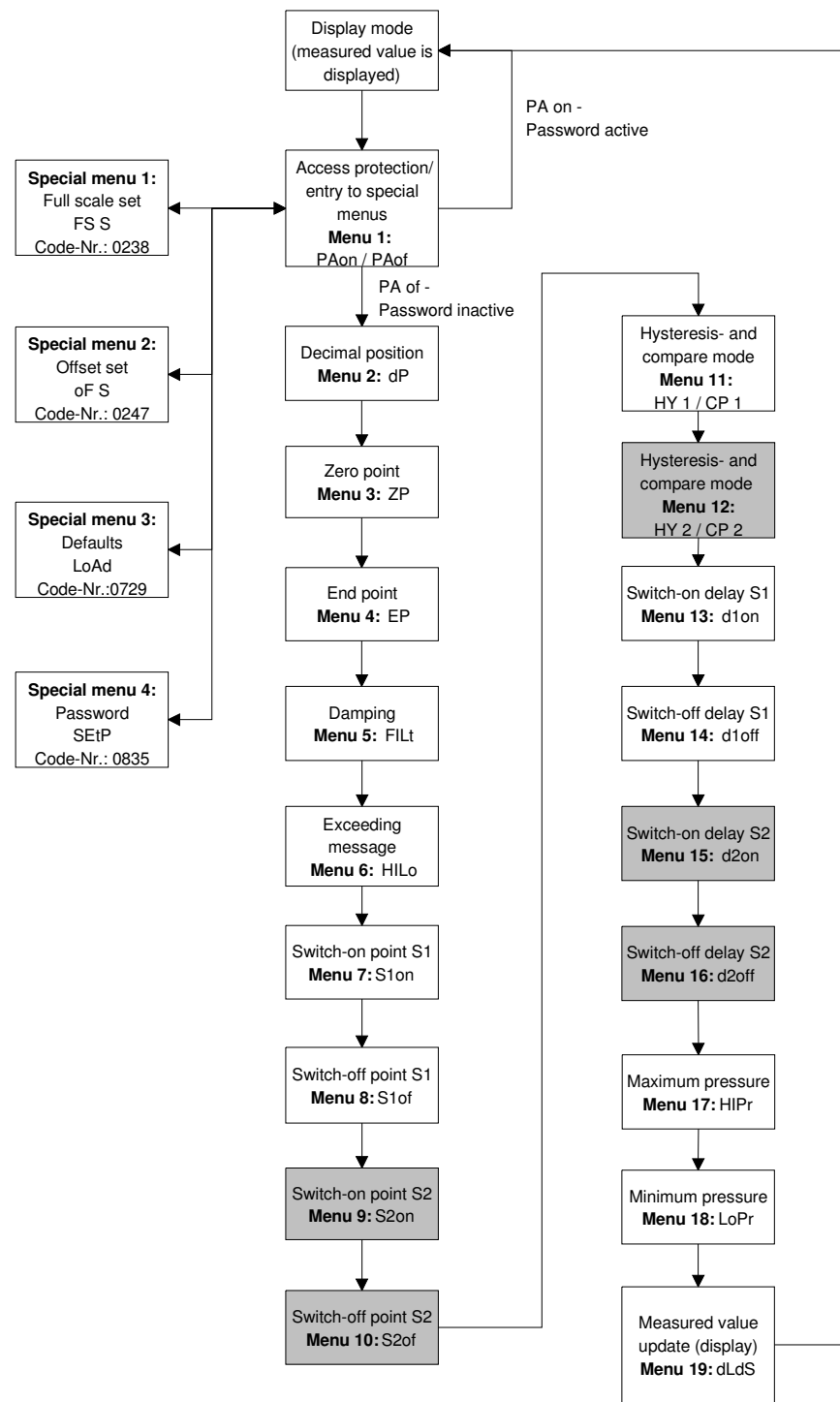

Fig. 8 hysteresis mode inverted



6.5 Menu list

- ▲-button: move in the menu system (forward) or increase the displayed value; it will also lead you to the operating mode (beginning with menu 1)
- ▼-button: move in the menu system (backward) or decrease the displayed value; it will also lead you to the operating mode (beginning with the last menu)
- both buttons simultaneously: confirm the menu items and set values
- ☒ to increase the counting speed, when setting the values: keeping the respective button pushed for more than 5 seconds

execution of configuration:

- set the desired menu item by pushing the ▲- or ▼-button
- activate the set menu item by pushing both buttons simultaneously
- set the desired value or select one of the offered settings by using the ▲- or ▼-button
- store/confirm the set value/selected setting and exit the menu by pushing both buttons simultaneously

PAon PAof	menu 1 – access protection PAon → password active → to deactivate: set password PAof → password inactive → to activate: set password ☒ default setting for the password is "0005"; modification of the password is described in special menu 4
dP	menu 2 – set decimal point position
ZP EP	menus 3 and 4 – set zero point / end point the device has been configured correctly before delivery, so a later setting is only necessary, if a differing displayed value is desired (e. g. 0 ... 100 %)
FILt	menu 5 – set damping this function allows getting a constant display value although the measuring values may vary considerably; the time constant for a simulated low-pass filter can be set (0.3 up to 30 sec permissible)
HILo	menu 6 – exceeding message set "on" or "off"
S1on S1of	menus 7 and 9 – set switch-on points (only for DS 230) set the particular values, for the activation of contact 1 (S1on) up to 2 (S2on) menus 8 and 10 – set switch-off points (only for DS 230) set the particular values, for the deactivation of contact 1 (S1of) up to 2 (S2of)
HY 1 CP 1	menus 11 and 12 – select hysteresis or compare mode (only for DS 230) select the hysteresis mode (HY 1 up to HY 2) or compare mode (CP 1 up to CP 2) for the contacts 1 up to 2 (no. corresponds to the contact) ☒ compare "6.5. Description of hysteresis and compare mode"
d1on	menus 13 and 15 – set switch-on delay (only for DS 230) set the particular value of the switch-on delay after reaching contact 1 (d1on) up to 2 (d2on) (0 up to 100 sec permissible)
d1of	menus 14 and 16 – set switch-off delay (only for DS 230) set the particular value of the delay after reaching the switch-of point 1 (d1of) up to 2 (d2of) (0 up to 100 sec permissible)
HIPr LoPr	menus 17 and 18 – maximum / minimum pressure display view high pressure (HIPr) or low pressure (LoPr) during the measurement process (the value will not remain stored if the power supply is interrupted) ☒ to erase: push both buttons again within one second
dLdS	menu 19 – measured value update (display) set the length of the update cycles for the display (0.0 up to 10 sec permissible)
special menus (to access a special menu, select the menu item "PAof" with the ▲- or ▼-button and confirm it; "1" appears in the display)	
FS S	special menu 1 – full scale compensation for full scale compensation, which is necessary if the indicated value for full scale differs from the real full scale value in the application; a compensation is only possible with a respective reference source, if the deviation of the measured value is within defined limits; set "0238"; confirm with both buttons; "FS S" will appear in the display; now it is necessary to place the device under pressure (the pressure must correspond to the end point of the pressure measuring range); push both buttons, to store the signal being emitted from the pressure gauge as full scale; in the display the set end point will appear although the full scale sensor signal is displaced ☒ the analogue output signal (for devices with analogue output) is not affected by this change
of S	special menu 2 – offset compensation / position correction set "0247"; confirm menu item; if offset ≠ ambient pressure it is necessary to place the device under pressure (pressure reference has to correspond to the zero point of the pressure measuring range); push both buttons to store the signal being emitted from the pressure gauge as offset; in the display the set zero point will appear although the sensor signal in the offset is displaced ☒ a position correction is necessary, if the installation position differs from the calibration position (otherwise this can cause a little deviation of the signal, which gives a wrong value indication) ☒ the analogue output signal (for devices with analogue output) is not affected by this change; when displacing the offset, the full scale will also be displaced
LoAd	special menu 3 – load defaults set "0729"; to load the defaults, push both buttons simultaneously ☒ any changes carried out will be reset (password will be set on "0005")
SEtP	special menu 4 – set password set "0835"; confirm with both buttons; "SEtP" appears in the display; set the password using the ▲- or ▼-button (0 ... 9999 are permissible, the code numbers 0238, 0247, 0729, 0835 are exempt); confirm the password by pushing both buttons simultaneously

7. Placing out of service

- ⚠ **WARNING!** When dismantling the device, it must always be done in the depressurized and currentless condition! Check also if the medium has to be drained off before dismantling!
- ⚠ **WARNING!** Depending on the medium, it may cause danger for the user. Comply therefore with adequate precautions for purification.

8. Maintenance

In principle, this device is maintenance-free. If desired, the housing of the device can be cleaned when switched off using a damp cloth and non-aggressive cleaning solutions.

- ! An incorrect cleaning can cause irreparable damages on diaphragm. Never use spiky objects or pressured air for cleaning the diaphragm.

9. Service / Repair

9.1 Recalibration

During the life-time of the device, the value of offset and span may shift. As a consequence, a deviating signal value in reference to the nominal pressure range starting point or end point may be transmitted. If one of these two phenomena occurs after prolonged use, a recalibration is recommended to ensure furthermore high accuracy.

9.2 Return

Before every return of your device, whether for recalibration, decalcification, modifications or repair, it is necessary to contact us to ensure a fast handling of your request. Please inform us by sending an email to: return@bdsensors.de. Include the number of devices sent and request a RMA. Then clean the device and pack it shatterproof before send it to BD SENSORS indicating the RMA.

10. Disposal

The device must be disposed according to the European Directives 2002/96/EG and 2003/108/EG (on waste electrical and electronic equipment) Waste of electrical and electronic equipment may not be disposed by domestic refuse!



- ⚠ **WARNING!** Depending on the measuring medium, deposit on the device may cause danger for the user and the environment. Comply with adequate precautions for purification and dispose of it properly.

11. Warranty conditions

The warranty conditions are subject to the legal warranty period of 24 months from the date of delivery. In case of improper use, modifications of or damages to the device, we do not accept warranty claims. Damaged diaphragms will also not be accepted. Furthermore, defects due to normal wear are not subject to warranty services.

12. Declaration of conformity / CE

The delivered device fulfils all legal requirements. The applied directives, harmonised standards and documents are listed in the EC declaration of conformity, which is available online at: <http://www.bdsensors.com/products/download/certificates>. Additionally, the operational safety is confirmed by the CE sign on the manufacturing label.